

-YANMAR EF 235- franthef

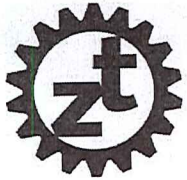

ZUIDBERG

FRONTLINE SYSTEMS

Buitenveld 5
8307 DE Ens (N.O.P)
The Netherlands
T +31 (0) 527 253550
F +31(0) 527 253037

www.zuidberg.com

Montage Instructies

Mounting Instructions

Montage Anleitung

Notice de Montage

	Eerst de frontaftakas monteren!
	First fit the PTO!
	Erst die Frontzapfwellenanlage montieren!
	Montez d'abord la prise de force

A.u.b. hier serienummer opschrijven:
Please write down the serial number here:
Bitte hier die Seriennummer hinschreiben:
Notez le numéro de série ici s.v.p.:

_____ . _____

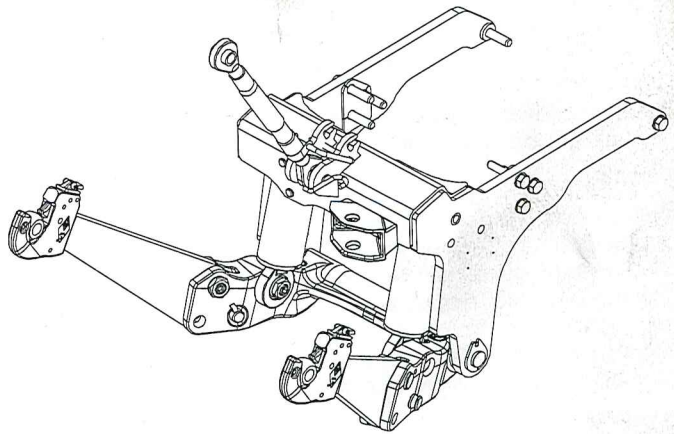
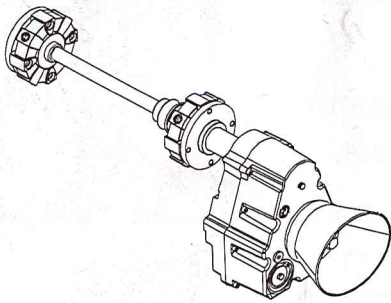

Specifications:

Customer: _____

Product: 14031590: LIN_YANMAR_GMS2_CAT0_6KN

Print date: 1-12-2017

Klantgegevens
 Customer Information
 Kundendaten
 Information du client





Belangrijk - Important - Wichtig - Vigtigt

Nederlands

NL

Volg stapsgewijs de instructies in dit montagevoorschrift op.
Let goed op verwijzingen naar de montagetekening en bijlagen.
Draai bouten vast met de aangegeven aandraaimomenten.
Denk bij montage van hydraulische slangen en / of kabels om de uitlaat (hitte) en roterende / bewegende delen.
Peil na montage de olie van frontaftakas.
Neem contact op met uw leverancier in geval van onduidelijkheden, het ontbreken van onderdelen of onjuiste levering.

English

UK

Follow the instructions stepwise.
Attend the references to the assembly drawing and the enclosures.
Fasten all bolts with the specified torque setting.
Attend the exhaust (heat) and rotating parts when mounting cables and hydraulic hoses.
Check oil of the PTO after assembly.
Contact your supplier in case of indistinctnesses, missing parts or incorrect delivery.

Deutsch

DE

Anweisungen befolgen.
Seid aufmerksam für Verweisungen.
Die Bolzen anziehen mit den spezifizierten Anziehdrehmomenten.
Seid aufmerksam für den Auspuff (Hitze) und bewegte und rotierende Teile, wenn man Kabels und Hydraulische Släuche montiert.
Kontrolliere den Ölstand des Zahnradgetriebes nach der Montage.
Kontakt aufnehmen mit Ihrem Lieferant im Fall der Undeutlichkeiten, das Fehlen von Ersatzteilen oder unrichtige Lieferung.

Français

FR

Suivez les instructions de montage pas à pas.
Reportez-vous aux plans de montage et aux annexes.
Serrez les vis au couple indiqué.
Veillez à éloigner les flexibles hydrauliques, les câbles etc. de l'échappement et de toute pièce en mouvement.
Vérifiez le niveau de la prise avant après le montage.
Contactez votre fournisseur au cas ou quelque chose vous semble peu clair, où s'il y a des pièces manquantes.

Dansk

DK

Følg anvisningerne trinvist.
Vær opmærksom på referencer til samleillustrationen og bilag.
Spænd alle bolte i henhold til angivne tal for spænding.
Vær opmærksom på udstødning (varme) og roterende dele ved montering af kabler og hydrauliske slanger.
Kontroller oliestand efter samling.
Kontakt din forhandler ved tvivl, manglende dele eller forkert levering.

Italiano

I

Seguire passo a passo le istruzioni di montaggio.
Attenersi scrupolosamente ai riferimenti nel disegno di montaggio e nei supplementi.
Serrare la bulloneria secondo le coppie di serraggio previste.
Nel montare i tubi idraulici e o i cavi tenere in considerazione i rischi derivanti dallo scappamento (calore) e dalle parti in movimento.
Controllare il livello dell'olio della presa di forza dopo il montaggio.
Contattate il vostro fornitore in caso di dubbi, pezzi mancanti o forniture irregolari.

Espanol

ESP

Sigan las instrucciones de montaje paso a paso.
Preste especial atención a las referencias que se hacen al dibujo de montaje y a los apéndices.
Apriete los pernos con los momentos de torsión indicados.
Preste atención al escape (calor) y a los componentes rotatorios / en movimiento durante el montaje de las mangueras y/o cables hidráulicos.
Mida el nivel de aceite de la toma de fuerza frontal después del montaje.
Póngase en contacto con su proveedor si tiene dudas, si faltan componentes o en caso de una entrega incorrecta.

Português

POR

Siga as instruções.
Tenha atenção às referências existentes no desenho de montagem e nas tampas.
Aperte todos os parafusos com o binário especificado.
Tenha atenção ao escape (calor) e às peças rotativas quando montar os cabos e mangueiras.
Verifique o óleo da TDF depois da montagem.
Contacte o fornecedor em caso de falta de informação, peças inexistentes ou entrega incorrecta.

1

- NL** Demonteer de gewichtendrager.
- EN** Dismount weightcarrier, batterie and batteriplate.

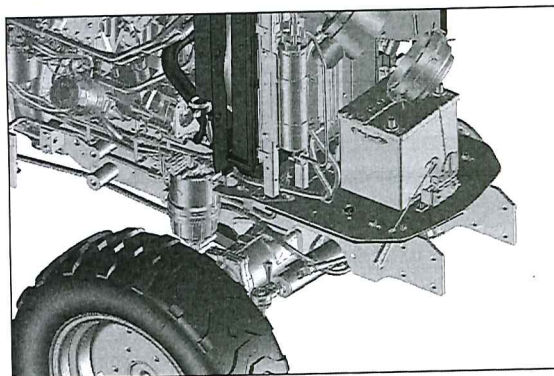

2

- NL**
 1. Monteer de spacer met de pinnen aan het hefframe.
 2. De pinnen mogen niet uitsteken.
- EN**
 1. Install the spacers with the pins to the hitchframe.
 2. The pins may not stick out.

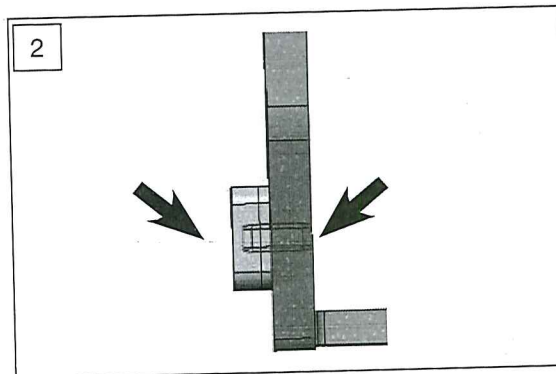
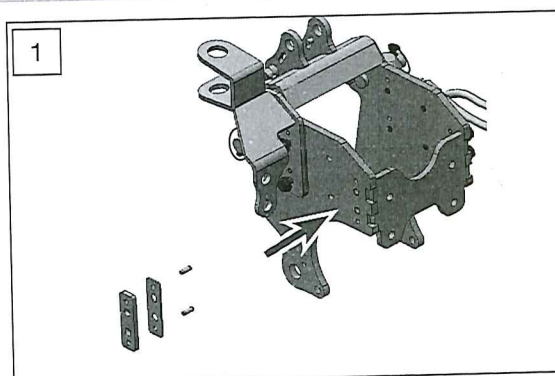



3

NL

1. Monteer de unit aan het trekkerchassis. Vergeet niet de spacers te monteren.
2. Monteer de uitlaatafscherming.

EN

1. Install the unit to the chassis. Don't forget to install the spacers.
2. Install protectionplate near exhaustpipe.

10 x M12 10.9 123 Nm

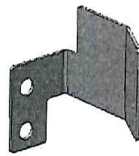

2 x M12 10.9 123 Nm

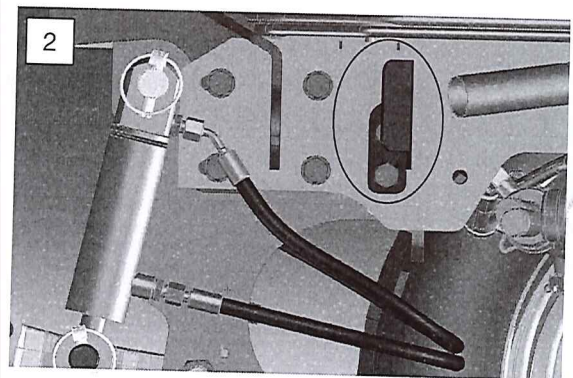
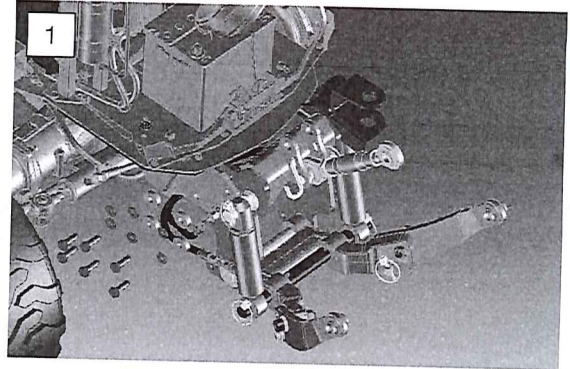

4 Hose routing

NL

Monteer de slanggeleiders zoals aangegeven.

EN

Install hoseguides as indicated.

DE

FR

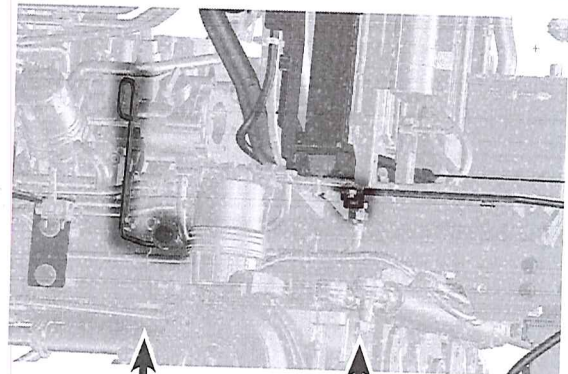

5

- NL** Monteer de kogelkraan met de geleverde montagebeugel.
- EN** Install valve with bracket.

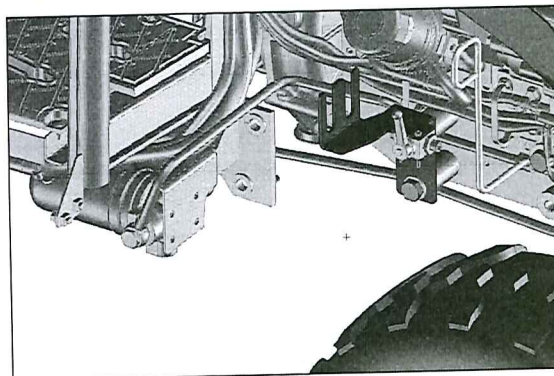

6

- NL** Monteer de front snelkoppelingen.
- EN** Install quick couplers

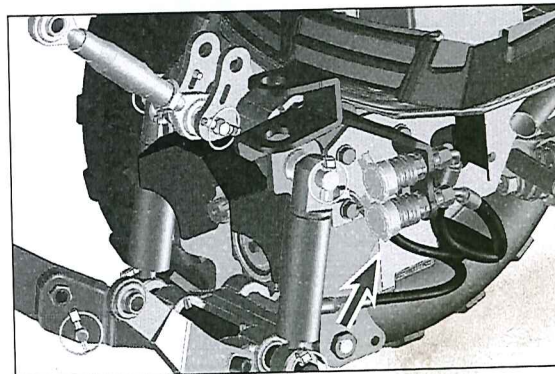



7

- NL** Geleid de slangen volgens onderstaande afbeeldingen.
- EN** Guide Hydraulic hoses according to following drawings.

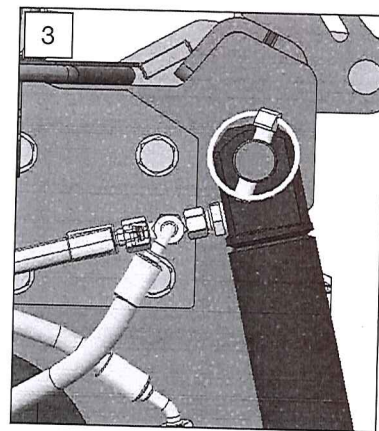
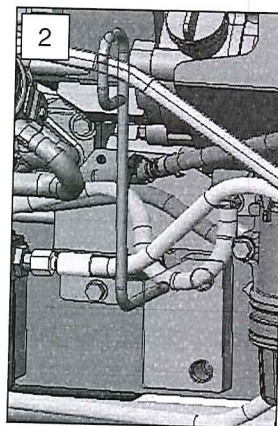
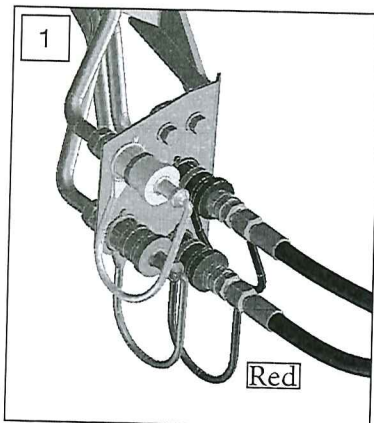
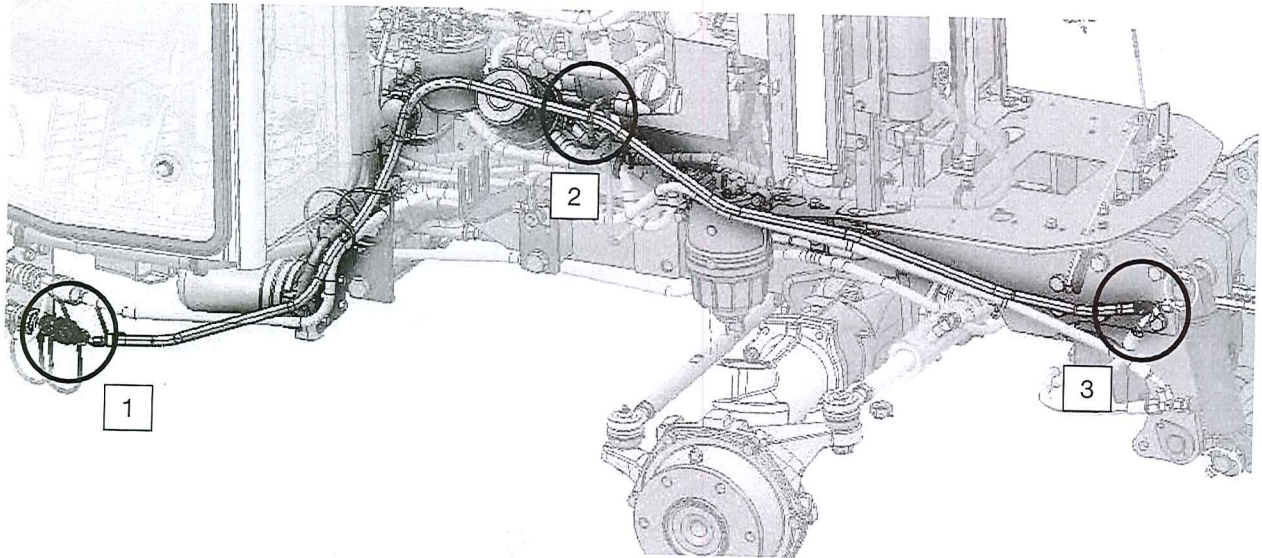

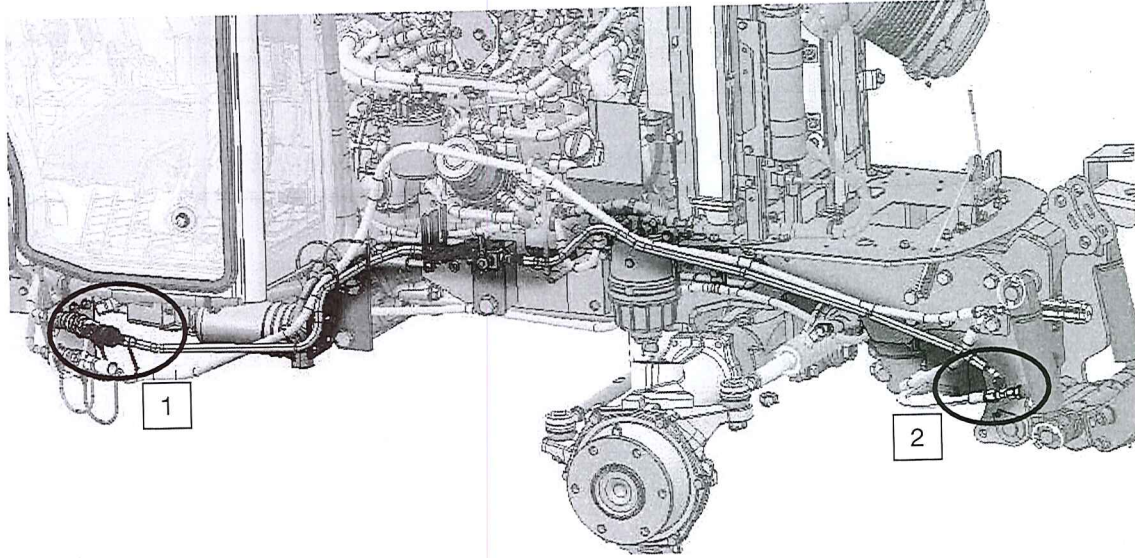

v

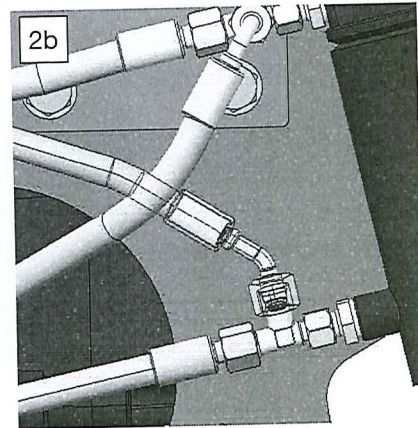
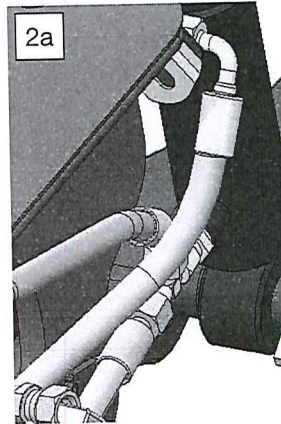
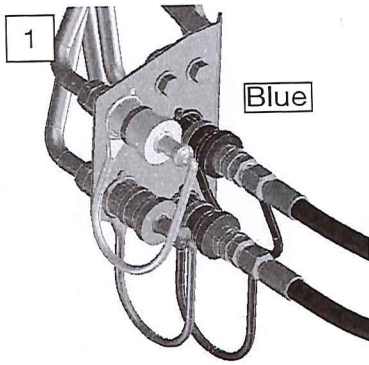

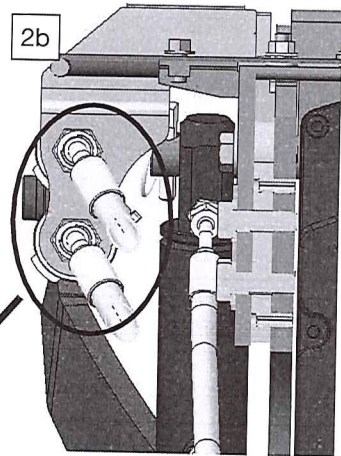
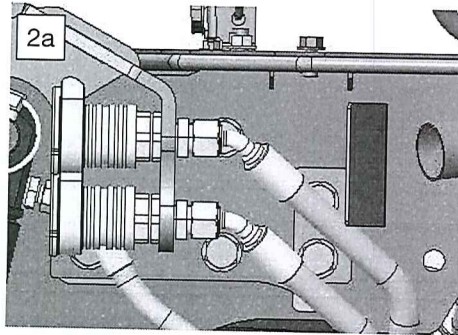
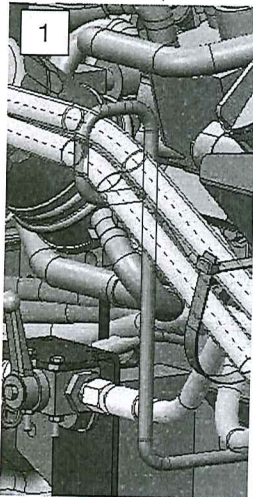
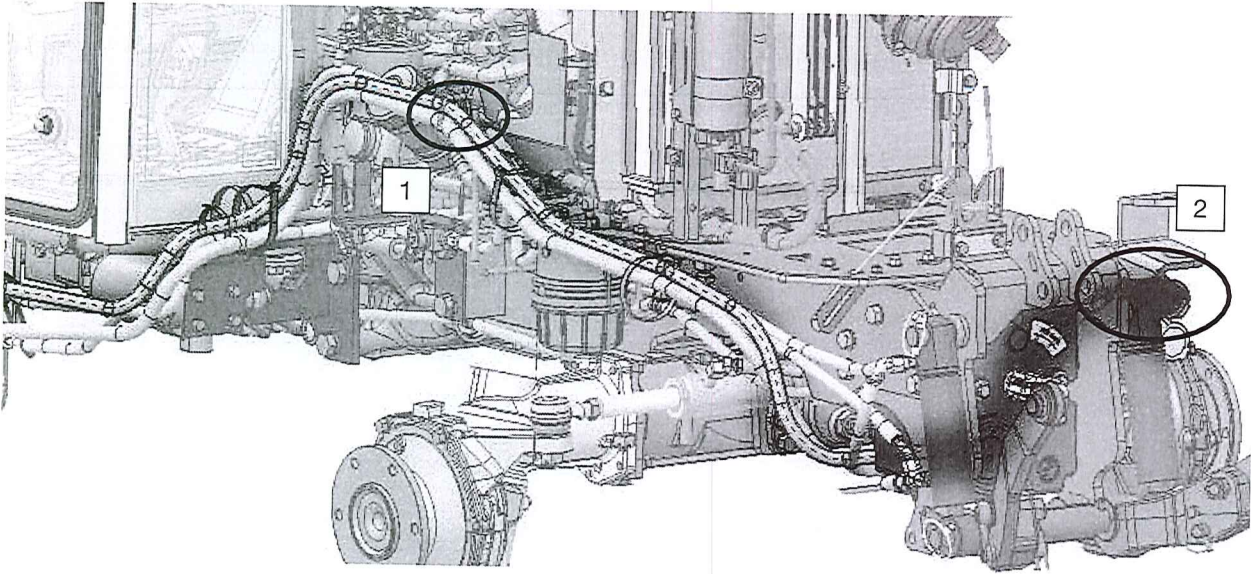

NL Draai koppeling 20 a 30 graden naar binnen.
EN Rotate couplers 20 to 30 degrees inwards.

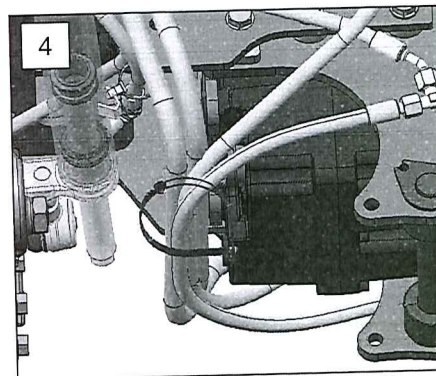
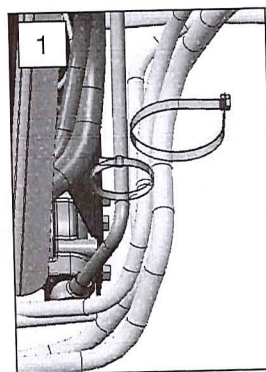
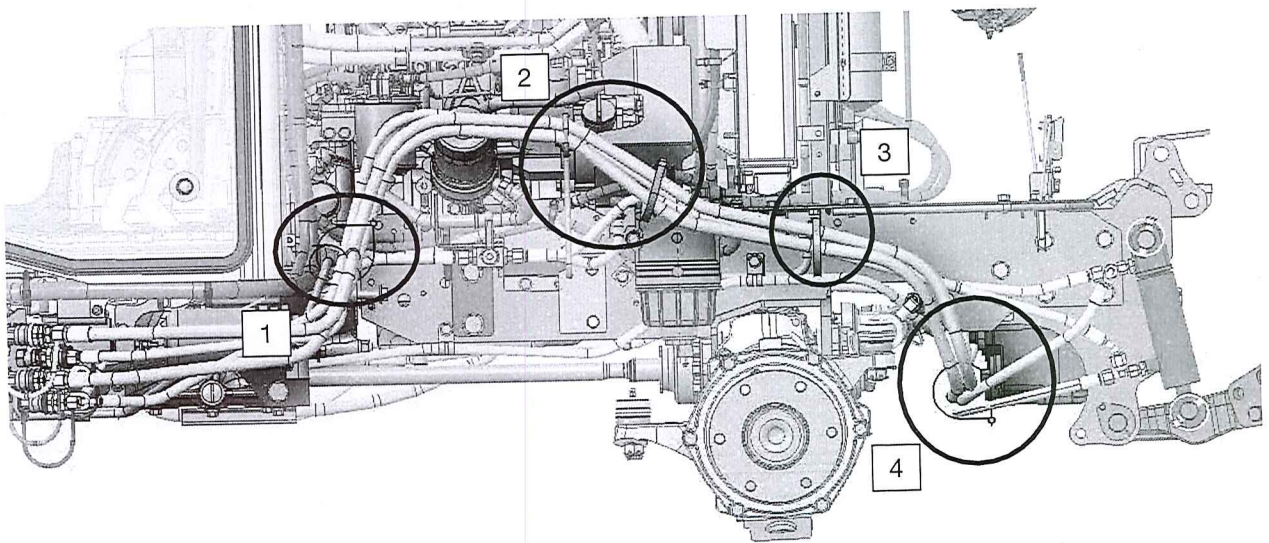
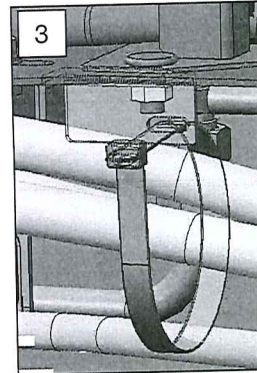
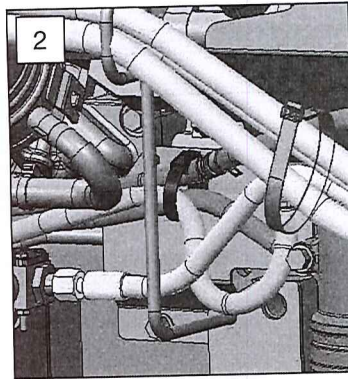



8 7-polige trailerconnector

- NL** 7-polige trailerconnector.
- EN** 7-pole Connector

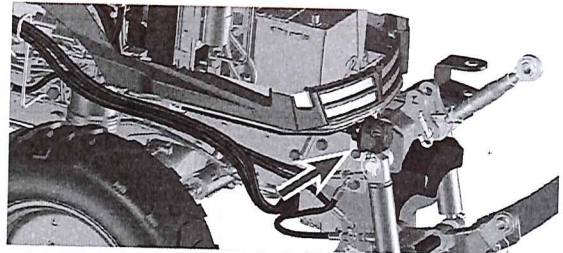

9 Accumulator

- NL** Accumulator
- EN** Accumulator

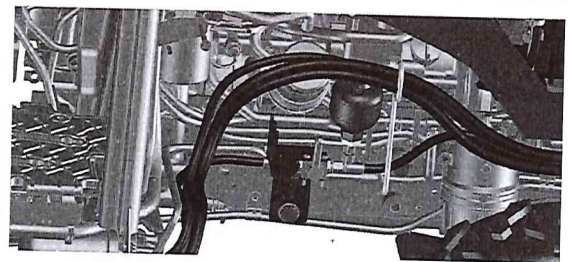

10 Pushbar

- NL** Monteer de bevestigingsplaat op het transmissiehuis. Vergeet de spacers niet.
- EN** Install mountingplate on transmission housing. Don't forget the spacers.

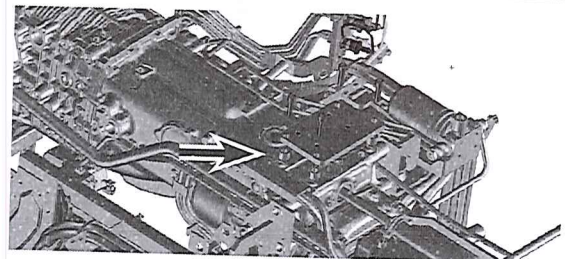

11

- NL** Monteer de pushbar tussen de hef en de bevestigingsplaat. Draai de bouten handvast aan.
- EN** Install the pushbar between the hitch and the mountingplate. Fasten the bolts by hand.

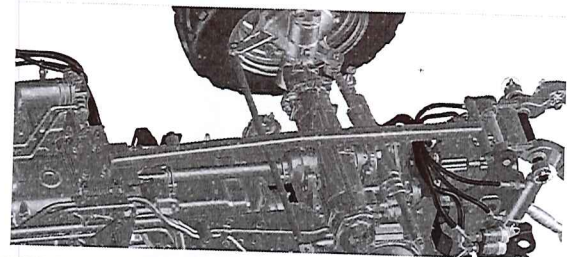

12

- NL** Draai met de aangegeven bouten de speling uit de constructie.
- EN** Give pre-tension by fasten the bolts.

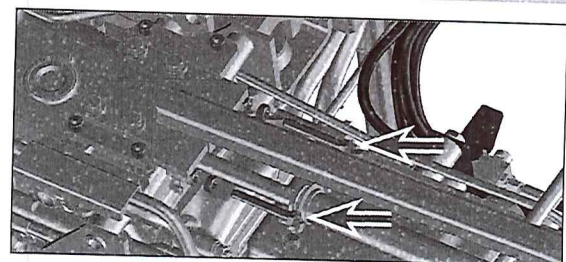



13

NL Draai tot slot alle bouten aan op het aanhaalmoment volgens tekening.

EN Fasten all bolts with the right torque according to the drawings.

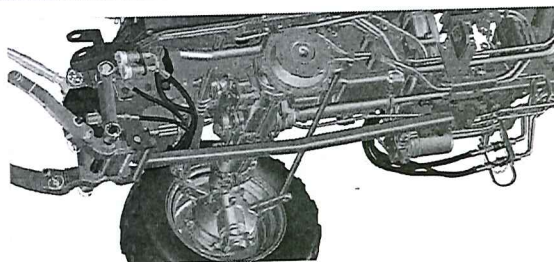

Aanhaalmomenten/ Torque settings/ Anzieldrehmomenten/ Couple de serrage



NL Let op! Hanteer de onderstaande waarden, **tenzij** anders vermeld op de tekening.
UK Attention! Apply the following values, **unless** specified on the drawing.
DE Achtung! Verwenden Sie die folgenden Werte, **wenn nicht** in der Zeichnung angegeben.
FR ATTENTION ! Utiliser les valeurs ci-dessous, sauf si indiqué autrement sur le plan.

	8.8		10.9		12.9	
	Nm	Ft lb	Nm	Ft lb	Nm	Ft lb
M5	6	4	8	6	10	7
M6	10	7	15	11	18	13
M7	17	13	25	18	28	21
M8	25	18	35	26	42	31
M10	50	37	71	52	85	63
M12	87	64	123	91	147	108
M14	138	102	194	143	235	173
M16	211	156	299	221	358	264
M18	289	213	412	304	490	361
M20	412	304	579	427	696	513
M22	559	412	784	578	941	694
M24	711	524	1000	738	1196	882
M27	1049	774	1481	1092	1775	1309
M30	1422	1049	2010	1483	2403	1772

	8.8		10.9		12.9	
	Nm	Ft lb	Nm	Ft lb	Nm	Ft lb
M10 x 1.25	51	38	71	53	86	63
M12 x 1.25	92	68	131	97	156	115
M12 x 1.50	87	64	122	90	147	108
M14 x 1.50	146	108	206	152	247	182
M16 x 1.50	221	163	311	229	373	275
M18 x 1.50	319	235	449	331	539	398
M20 x 1.50	451	333	535	395	763	563
M22 x 1.50	598	441	877	647	1007	743
M24 x 2.00	760	561	1068	788	1284	947
M27 x 2.00	1129	833	1590	1173	1908	1407
M33 x 2.50	1930	1424	2715	2003	3265	2408

NL Bout metrisch draad standaard.
UK Bolt metric thread standard.
DE Schraube metrisch Gewinde Standard.
FR Vis métrique Pas standard.

NL Bout metrisch draad fijn.
UK Bolt metric thread fine.
DE Schraube metrisch Gewinde fein.
FR Vis métrique Pas fin.

	Nm	Ft lb
M20 x 1.50	200	148
M24 x 1.50	275	203
M27 x 1.50	350	258
M30 x 1.50	400	295
M33 x 1.50	410	302

NL Lage zeskantmoeren metrisch verzinkt
UK Flat hexagonal nuts, metric zinc-plated.
DE Flache Sechskantmuttern metrisch verzinkt.
FR Écrous hexagonaux bas, métriques, filet fin, zingués.



Aanhaalmomenten/ Torque settings/ Anziedhdrehmomenten/ Couple de serrage



NL Let op! Hanteer de onderstaande waarden, **tenzij** anders vermeld op de tekening.
UK Attention! Apply the following values, **unless** specified on the drawing.
DE Achtung! Verwenden Sie die folgenden Werte, **wenn nicht** in der Zeichnung angegeben.
FR ATTENTION ! Utiliser les valeurs ci-dessous, sauf si indiqué autrement sur le plan.

	P		S		T	
	Nm	Ft lb	Nm	Ft lb	Nm	Ft lb
1 / 4"	5	4	10	7	11	8
5 / 16"	11	8	21	16	23	17
3 / 8"	20	15	38	28	41	30
7 / 16"	32	24	61	45	66	49
1 / 2"	49	36	93	69	100	74
9 / 16"	70	52	134	99	144	106
5 / 8"	97	72	185	136	200	148
3 / 4"	178	131	338	249	364	269
7 / 8"	279	206	530	391	572	422
1"	418	308	795	586	858	633
1.1 / 8"	593	437	1126	831	1216	897
1.1 / 4"	837	617	1591	1174	1717	1266
1.3 / 8"	1096	808	2083	1536	2248	1658
1.1 / 2"	1456	1074	2767	2041	2987	2203

	P		S		T	
	Nm	Ft lb	Nm	Ft lb	Nm	Ft lb
1 / 4"	8	6	12	9	13	10
5 / 16"	12	9	24	18	26	19
3 / 8"	23	17	43	32	47	35
7 / 16"	36	27	68	50	74	55
1 / 2"	55	41	105	77	114	84
9 / 16"	79	58	150	111	162	120
5 / 8"	111	82	210	155	227	167
3 / 4"	195	144	370	273	399	294
7 / 8"	309	228	587	433	634	468
1"	459	339	873	644	942	695

NL Bout UNC draad standaard.
UK Bolt UNC thread standard.
DE Schraube UNC Gewinde Standard.
FR Vis UNC Pas standard.

NL Bout UNC draad fijn.
UK Bolt UNC thread fine
DE Schraube UNC Gewinde fein.
FR Vis UNC Pas fin.

Aanhaalmomenten/ Torque settings/ Anziedrehmomenten/ Couple de serrage



NL Let op! Hanteer de onderstaande waarden, **tenzij** anders vermeld op de tekening.
UK Attention! Apply the following values, **unless** specified on the drawing.
DE Achtung! Verwenden Sie die folgenden Werte, **wenn nicht** in der Zeichnung angegeben.
FR ATTENTION ! Utiliser les valeurs ci-dessous, sauf si indiqué autrement sur le plan.

	Nm	Ft lb
GE 8LR1/8"	25	18
GE 8LR1/4"	45	33
GE 8LR3/8"	85	63
GE 8LR1/2"	105	77
GE 8LM10	25	18
GE 8LM12	30	22
GE 8LM14	50	37
GE 8LM16	80	59
GE 8LM18	90	66
GE 12LR1/4"	45	33
GE 12LR3/8"	85	63
GE 12LR1/2"	105	77
GE 12LM12	30	22
GE 12LM14	50	37
GE 12LM16	60	44
GE 12LM18	90	66
GE 12LM22	150	111

	Nm	Ft lb
GE 15LR3/8"	85	63
GE 15LR1/2"	160	118
GE 15LM16	80	59
GE 15LM18	90	66
GE 15LM22	150	111
GE 15LM24	200	148
GE 18LR1/2"	105	77
GE 18LR3/4"	230	170
GE 18LM18	90	66
GE 18LM22	150	111
GEV 22LR3/4"	230	170
GEV 22LR1"	390	288
GEV 22M26	240	177

	Nm	Ft lb
PG 1/4"	50	37
PG 3/8"	85	63
PG 1/2"	105	77
PG M8	25	18
PG M10	30	22
PG M12	35	26
PG M14	40	30
PG M16	60	44
PG M18	80	59
PG M20	80	59
PG M22	120	89
PG M26	180	133

NL Inschroefkoppeling.
UK Coupling.
DE Einschraubverbindung.
FR Raccord.

	Nm	Ft lb
HP06 (SW17) M14x1.5	25	18
HP10 (SW22) M18x1.5	40	30

	Nm	Ft lb
SetScrew M12	35	26
(O-ring) fittings (24 deg) SWVE	70	52
Banjo M18x1,5 (de-areation bold alu)	40	30
ELBOW 8L	25	18
ELBOW 12L	40	30

	Nm	Ft lb
G1/2x38	40	30
M10x1,5	15	11
M16x1,5	70	52
M18x1,5	80	59
M22x1,5	140	103

NL Slangkoppeling.
UK Hose connection.
DE Schlaucharmaturen.
FR Raccord de flexible

NL Diversen.
UK Miscellaneous.
DE Verschiedenes.
FR Divers

NL Banjo bout.
UK Banjo bolt.
DE Hohlschraube.
FR Vis banjo.

www.zuidberg.com
 designed: 01/09/2017
 checked: 08/11/2017
 released: 08/11/2017
 weight (kg) 50
 projectnumber P1775

1403159 0
 LIN_YANMAR_GMS2_CATO_6KN
 YANMAR: 1A8406-08000

A3

Pos	Qty	Description	Article code	OEM Code	Remarks
1	1	LIN_U_YANMAR_GMS2_6KN	605178 A		
2	2	CUT_SPACER_2X_M12_8MM	2020308 0		S235JR
3	2	CUT_SPACER_2X_M12_3MM	2020309 0		DC01-A-m+ZE
4	6	BUSH_Ø35_Ø13_L11	2020306 0		C45
5	4	SPRING_PIN_8X20_ZN	7501205 0		
6	10	WASHER_M12_ZN	7500751 0		
7	10	BOLT_M12X_35_10.9_ZN	7001127 0		123 Nm
8	1	BND_EXHAUST_GUARD	2021807 0		DC01-A-m
100	1	HYDR_SET_YANMAR_GMS2	6030385 A		
600	0	XXXXXXXXXX OPTIONS XXXXXXXXXXXXX	0000112 0		
601	0	A_FRAME_CATO_360	1303967 0		
602	0	AC_0.16_8L_IN_LINE	1303582 0		
603	0	7P_FRONT_SET_YANMAR_GMS2	1303882 0		
604	0	PUSHBAR_YANMAR_GMS2	6070126 A		
605	0	LOADERKIT_YANMAR_GMS2	1303888 A		

Rev	USR	Date

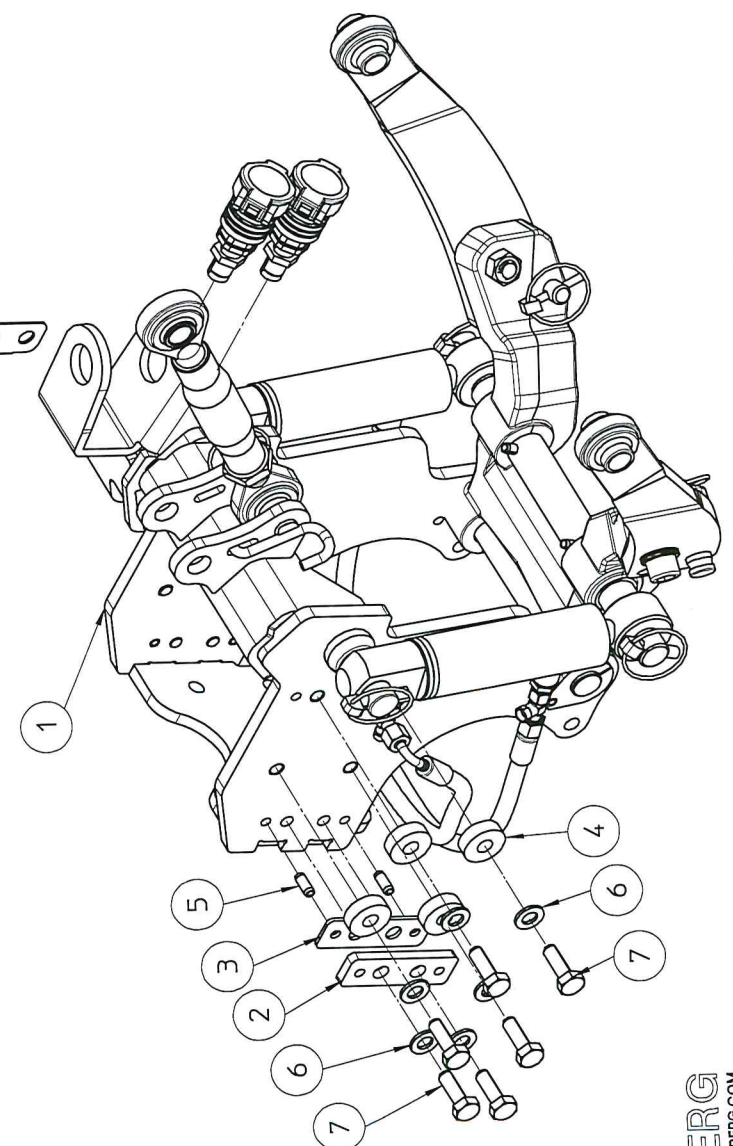
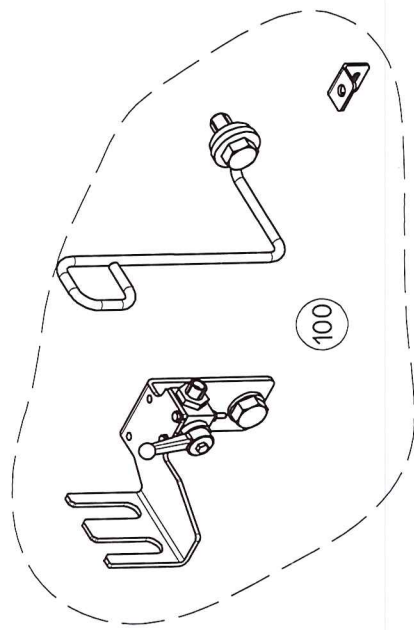

Disclaimer: The intellectual property rights and the know-how on the performed work and on all of the information and/or products provided by Zuidberg is forbidden, unless otherwise agreed by the parties in written form. The distribution, disclosure, copying or any other use of the information and/or products provided by Zuidberg is forbidden, unless otherwise agreed by the parties in written form.

Zuidberg Techniek B.V.

14031590: Partslist LIN YANMAR GMS2 CAT0 6KN

Pos	Aant	Art.code	Omschrijving	Mag.code
1	1	6051178A	LIN_U_YANMAR_GMS2_6KN	
2	2	20203080	CUT_SPACER_2X_M12_8MM	CMH_NIEUW
3	2	20203090	CUT_SPACER_2X_M12_3MM	CM06106
4	6	20203060	BUSH_IJ_35_IJ_13_L11	CMH_NIEUW
5	4	75012050	SPRING_PIN_8X20_ZN	2B_CMH
6	10	75007510	WASHER_M12_ZN	2B_CMTD/ZT
7	10	70011270	BOLT_M12X_35_10_9_ZN	2B_CMH
8	1	20218070	BND_EXHAUST_GUARD	CMH_NIEUW
100	1	6030385A	HYDR_SET_YANMAR_GMS2	
600	0	00001120	XXXXXXXXXX OPTIONS XXXXXXXXXXXX	0
601	0	13039670	A_FRAME_CATO_360	TL
602	0	13035820	AC_0.16_8L_IN_LINE	TL01H
603	0	13038820	7P_FRONT_SET_YANMAR_GMS2	CM44E06B
604	0	6070126A	PUSHBAR_YANMAR_GMS2	TL
605	0	1303888A	LOADERKIT_YANMAR_GMS2	TL

designated:	check:	release:	weight (kg)	part number	Rev	USR	Date
GZ	HC	GZ	45	F1775			

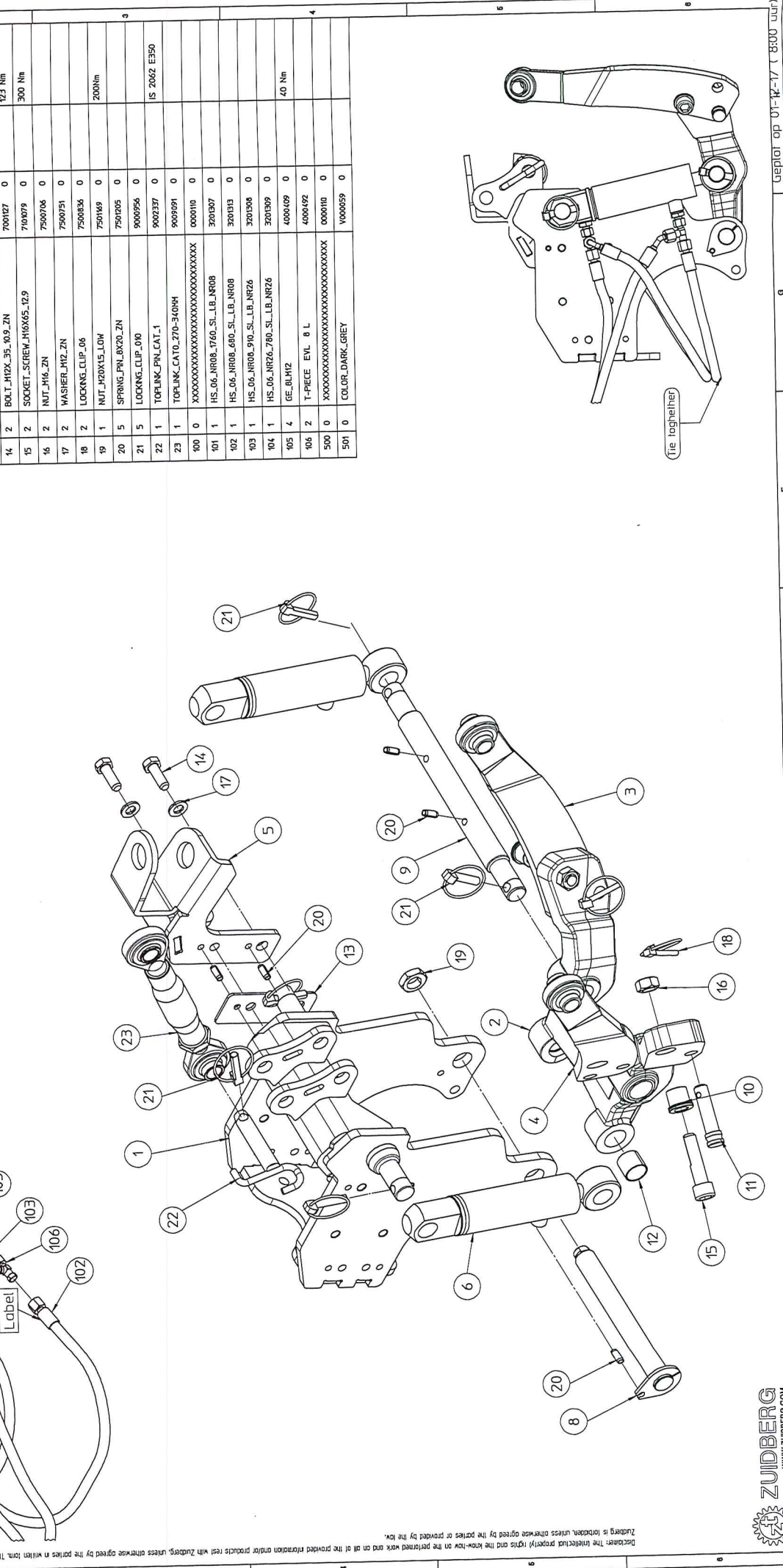

Zuidberg Techniek B.V.

6051178A: Partslist LIN U YANMAR GMS2 6KN

Pos	Aant	Art.code	Omschrijving	Mag.code
1	1	20203150	MNTRF_WELD_YANMAR_GMS2_6-8KN	SP
2	1	20138020	LIFT_FRAME_MACH_190_O30_CAT0-1	SP75
3	1	20167720	WLD_LIFT-ARM_L_BALL_EYE	SP12E
4	1	20167700	WLD_LIFT-ARM_R_BALL_EYE	SP12E
5	1	20203120	WLD_TOWINGHOOK_YANMAR_GMS2	SP
6	2	90011760	CYL_040x020x080_236_M12_06KN	SP04
7	0	00001100	XXXXXXXXXXXXXXXXXXXXXXXXXXXX	0
8	1	20067310	PIVOT_SHAFT_LF_190_FINAL	CM01L01A
9	1	20204330	CYLINDER_SHAFT_O25_O30_O25_L3	CM/M
10	2	20067210	BUSH_LIFTING-ARM_HEAVY-DUTY_GP	CM06E05A
11	2	2005900A	LOCKING_PIN_CAT_0_1	CM07E04C/M
12	2	90011750	BEARING_BUSH_PAP_2525_P10	CM02I03B/L
13	1	20203160	CUT_SPACER_TOWHOOK_3MM	SP
14	2	70011270	BOLT_M12X_35_10.9_ZN	2B_CMH
15	2	71010790	SOCKET_SCREW_M16X65_12.9	2B_CMH
16	2	75007060	NUT_M16_ZN	2B_CM_ZT
17	2	75007510	WASHER_M12_ZN	2B_CMTD/ZT
18	2	75008360	LOCKING_CLIP_06	CM02H04C
19	1	75011690	NUT_M20X1.5_LOW	2B_CMH
20	5	75012050	SPRING_PIN_8X20_ZN	2B_CMH
21	5	90009560	LOCKING_CLIP_010	CM02H4A/TD
22	1	90023370	TOPLINK_PIN_CAT_1	CM02H05F
23	1	90090910	TOPLINK_CAT0_270-340MM	CM07E02C
100	0	00001100	XXXXXXXXXXXXXXXXXXXXXXXXXXXX	0
101	1	32013070	HS_06_NR08_1760_SL_LB_NR08	
102	1	32013130	HS_06_NR08_680_SL_LB_NR08	
103	1	32013080	HS_06_NR08_910_SL_LB_NR26	
104	1	32013090	HS_06_NR09_780_SL_LB_NR26	

designed:	19/10/2016
checked:	31/08/2017
released:	31/08/2017
weight (kg)	
projectnumber	P1775

Pos	Qty	Description	Article code	OEM Code	Remarks
1	1	BEND_BALL_VALVE_BR_YANMAR_GMS2	2020307	0	S420MC
2	1	HOSE_GUIDE_STEEL_08	9002816	0	S235JR
3	1	BND_BRACKET_HOSE_GUIDE	2021731	0	DC01-A-m
4	2	WASHER_M16_ZN	7500709	0	
5	2	BOLT_M16X25_8.8_ZN	7000968	0	210 Nm
6	1	BALL_VALVE_PIPE_8L_SHORT	4001704	0	
7	2	BOLT_M4X45_8.8_ELVZ	7001077	0	3 Nm
8	2	NUT_M_4_ELVZ	7501017	0	
9	4	WASHER_M4_ZN	7501022	0	
10	2	QUICK_COUPLER_12L_+_BULKHEAD	4001107	0	
11	2	DUST_CAP_QUICK_COUPLER_YELLOW	4001157	0	
12	1	HS_10_NR02_2190_SL_LB_NR11	3201304	0	
13	1	HS_10_NR02_2200_SL_LB_NR03	3201305	0	
14	1	HS_06_NR08_790_SL_LB_NR08	3201306	0	
15	2	GE_8LR1/4	4000436	0	
16	2	GE_12LR1/4	4000461	0	
17	4	QUICK_COUPLER_NY1/4BSP	4001603	0	
18	6	TIE_WRAP_BLACK_7.6_250MM	7501720	0	
19	1	BOLT_M16X35_8.8_ZN	7501034	0	211 Nm
21	1	WASHER_M16_ZN_HEAVY_DUTY	7501006	0	

Rev	USR	Date
A	GDZ	2017/08/11

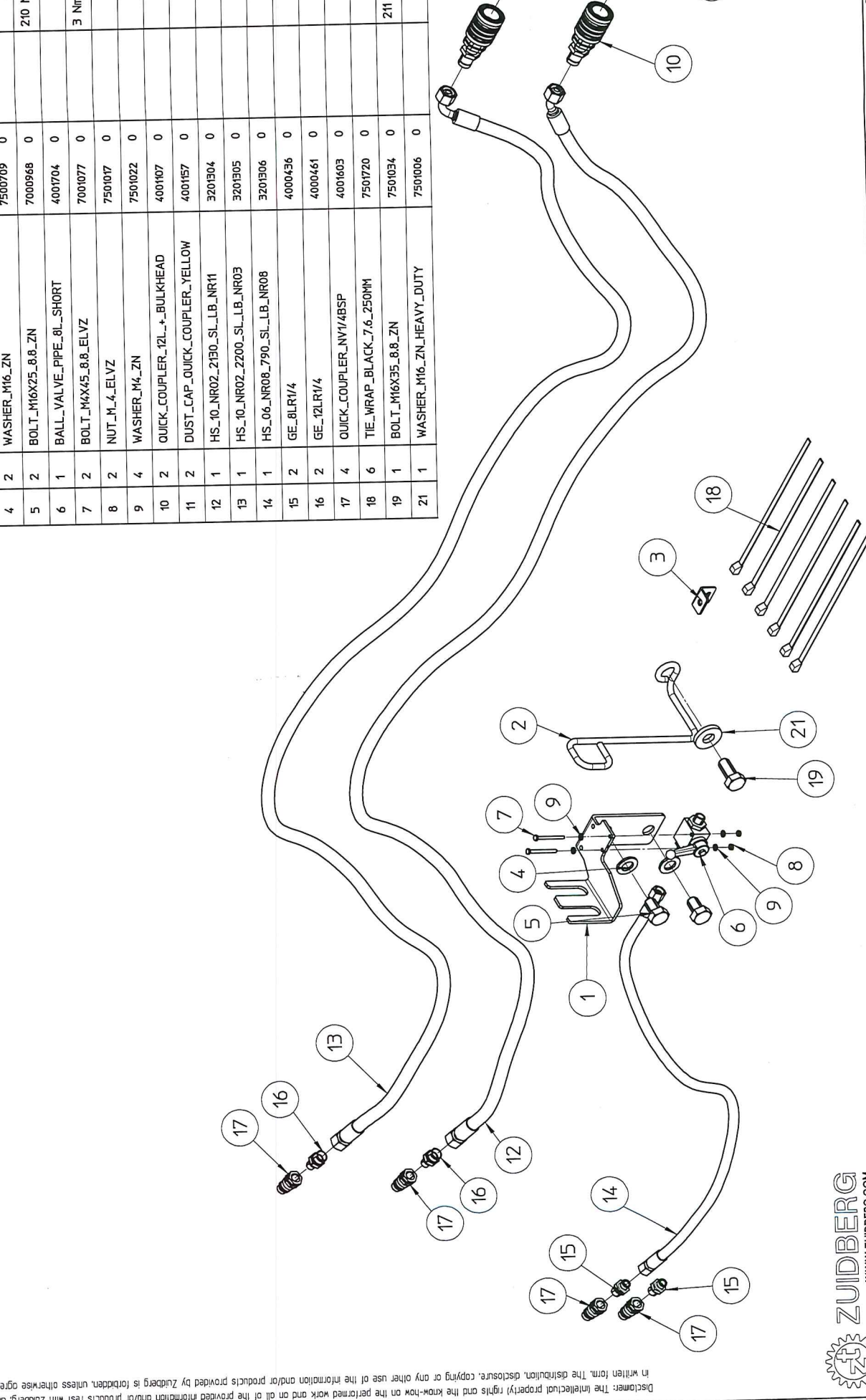

Zuidberg Techniek B.V.

6030385A: Partslist HYDR SET YANMAR GMS2

Pos	Aant	Art.code	Omschrijving	Mag.code
1	1	20203070	BEND BALL_VALVE_BR_YANMAR_GMS2	CM05F04
2	1	90028160	HOSE_GUIDE_STEEL_IJ 8	
3	1	20217310	BND_BRACKET_HOSE_GUIDE	CM06I04
4	2	75007090	WASHER_M16_ZN	2B_CM_ZT
5	2	70009680	BOLT_M16X25_8_8_ZN	2B_CM
6	1	40017040	BALL_VALVE_PIPE_8L_SHORT	CM04D02B
7	2	70010770	BOLT_M4X45_8_8_ELVZ	2B_CMH
8	2	75010170	NUT_M_4_ELVZ	2B_CMH
9	4	75010220	WASHER_M4_ZN	2B_CM
10	2	40011070	QUICK_COUPLER_12L+_BULKHEAD	CM08A03B
11	2	40011570	DUST_CAP_QUICK_COUPLER_YELLOW	CM08A03A
12	1	32013040	HS_10_NR02_2130_SL_LB_NR11	
13	1	32013050	HS_10_NR02_2200_SL_LB_NR03	
14	1	32013060	HS_06_NR08_790_SL_LB_NR08	
15	2	40004360	GE_8LR1/4	8B4D/41A5D
16	2	40004610	GE_12LR1/4	CM_BAK_4
17	4	40016030	QUICK_COUPLER_NW1/4BSP	CM08C02A
18	6	75017200	TIE_WRAP_BLACK_7.6_250MM	CM09
19	1	75010340	BOLT_M16X35_8_8_ZN	2B_CMH
21	1	75010060	WASHER_M16_ZN_HEAVY_DUTY	2B_CMH_ZT

designed: 19/10/2016
 checked: MC 25/09/2017
 released: GDZ 25/09/2017
 weight (kg) 11.3
 projectnumber P1775

Pos	QTY	Description	Article code	OEM Code	Remarks
1	1	WELD_PUSHBAR_YANMAR_GMS2	2020323	A	
2	1	BT_MOUNTINGPLATE_PB_YANMAR_GMS2	2020324	A	S420MC
3	0	XXXXXXXXXXXXXXXXXXXXXXXXXXXX	0000110	0	
4	4	BUSH_Ø25_Ø13_L16	2020325	0	C45
5	4	SOCKET_SCREW_M12X45_10.9_ZN	7501975	0	122 Nm
6	6	BOLT_M12X30_10.9_ZN	7001196	0	122 Nm
7	4	WASHER_M12_HEAVY_ZN	7500752	0	
8	2	WASHER_M12_ZN	7500751	0	
9	2	NUT_M12_ZN	7500789	0	
10	2	BOLT_FT_M12X80_8.8_ZN	7001018	0	87 Nm
500	0	XXXXXXXXXXXXXXXXXXXXXXXXXXXX	0000110	0	
501	0	COLOR_DARK_GREY	V000059	0	

Rev	USR	Date
A	GDZ	2017/08/11

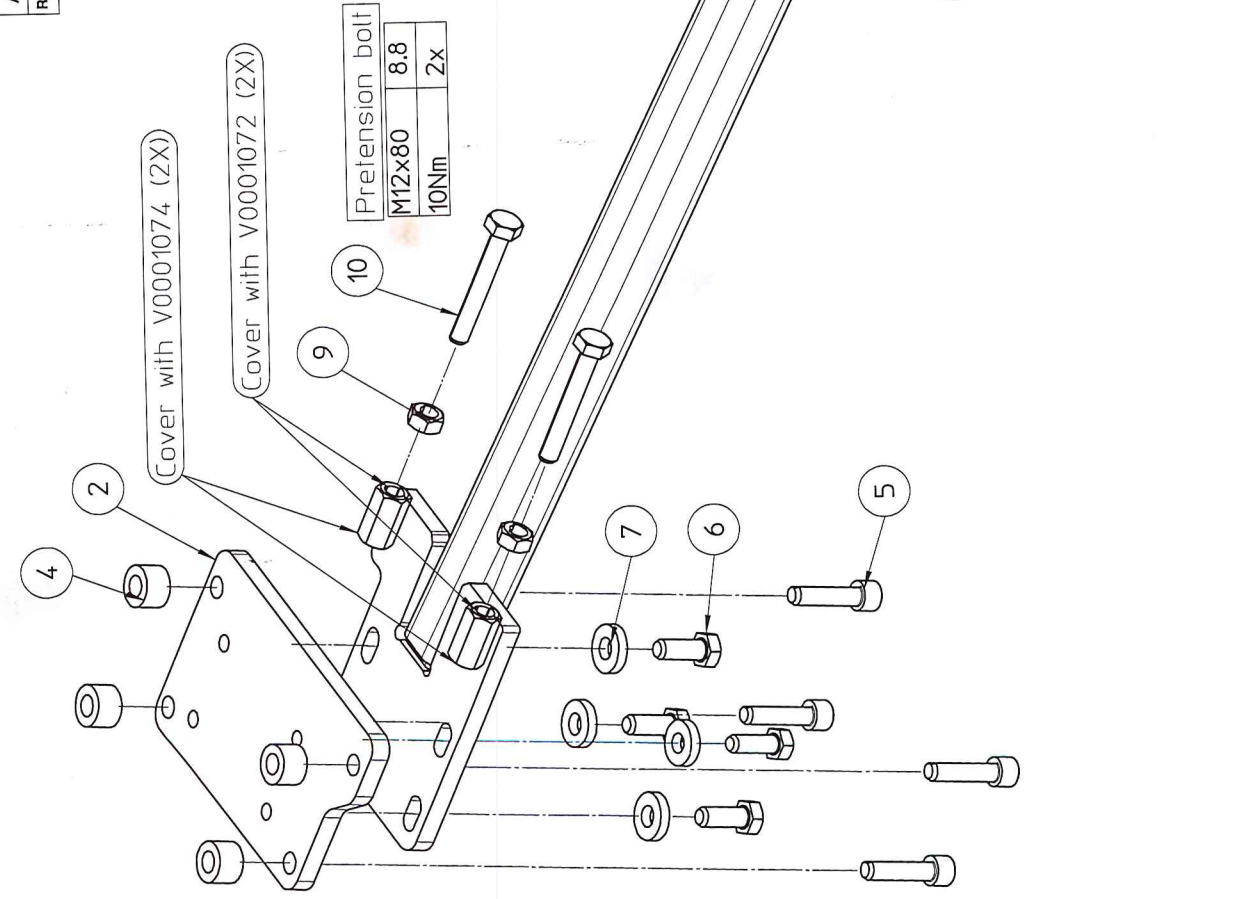

Pre-tension bolt
 M12x80 8.8
 10Nm 2x

Cover with V0001074 (2X)

Cover with V0001072 (2X)

Disclaimer: The intellectual property rights and the know-how on the performed work and on all of the provided information and/or products provided by Zuidberg is/are provided by Zuidberg, unless otherwise agreed by the parties in written form. The distribution, disclosure, copying or any other use of the information and/or products provided by Zuidberg is/are provided by Zuidberg, unless otherwise agreed by the parties.

Zuidberg Techniek B.V.

6070126A: Partslist PUSHBAR YANMAR GMS2

Pos	Aant	Art.code	Omschrijving	Mag.code
1	1	2020323A	WELD_PUSHBAR_YANMAR_GMS2	SP
2	1	2020324A	BT_MOUNTINGPLATE_PB_YANMAR_GM	SP
3	0	00001100	XXXXXXXXXXXXXXXXXXXXXXXXXXXXX	0
4	4	20203250	BUSH_J 25_J 13_L16	CM06I04
5	4	75019750	SOCKET_SCREW_M12X45_10.9_ZN	CMH_2B_NEW
6	6	70011960	BOLT_M12X30_10.9_ZN	2B_ZT
7	4	75007520	WASHER_M12_HEAVY_ZN	2B_CM
8	2	75007510	WASHER_M12_ZN	2B_CMTD/ZT
9	2	75007890	NUT_M12_ZN	2B_CM
10	2	70010180	BOLT_FT_M12X80_8.8_ZN	2B_CMH
500	0	00001100	XXXXXXXXXXXXXXXXXXXXXXXXXXXXX	0
501	0	V0000590	COLOR_DARK_GREY	SP